

easee

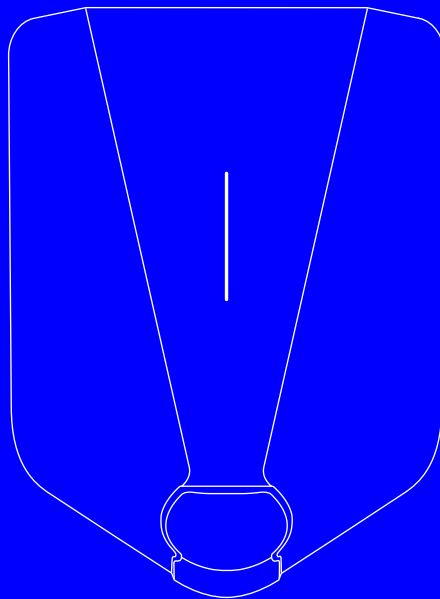

User guide / Installation guide

Easee Plug & Play

Table of contents

Introduction

Introduction	3
Product overview	3
Features	4
Technical specifications	5

Safety

Safety instructions	6
---------------------	---

Installation

Installation instructions	7
---------------------------	---

Daily use and operation

How do I charge?	10
Apps and interfaces	10
Charging Robot interface	11
Maintenance	12
Practical details	12

IMPORTANT:

Read carefully before use. Keep for future reference.

Introduction

Easee Plug & Play includes a Chargeberry and a front cover. With our innovative Easee Plug & Play technology, you can transform your pre-installed Easee Ready backplate into a fully functional Charging Robot for your electrically powered vehicle.

Intended use

This product is intended solely for charging electrically powered vehicles equipped with non-gassing batteries (e.g. lead-acid batteries).

The product shall only be used with a charging cable according to IEC 62196. The product must be firmly mounted on a wall or structure that covers the entire back side of the product and has a sufficient load-bearing capacity. It may only be operated with the approved operating parameters and under the specified environmental conditions (see page 5).

Uses other than those specified here are not permitted.

Conventions



This symbol indicates that the respective instructions must only be carried out by an authorised electrician.



This symbol indicates an immediate danger to life and health of individuals due to the effects of electrical energy. Non-observance of these instructions will result in serious damage to health - up to and including life-threatening injuries.

Product overview

Front cover

Protects the electronics from external influences.

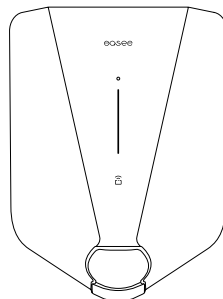

Chargeberry

Contains the electronics for charging the vehicle.

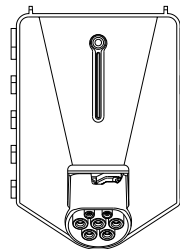

Tool

Used for removing the front cover, after the screw has been removed.



Features

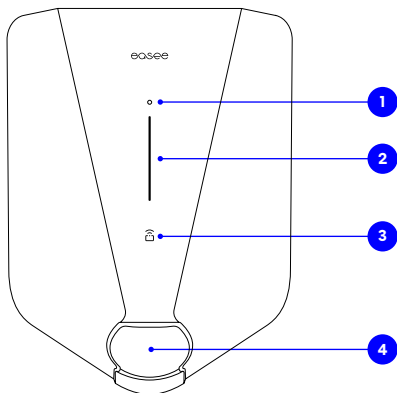

- 1. Touch button:** The touch button is used to activate the WiFi interface which is then used to configure the backplate during installation. This should already have been done by a certified electrician. Now the WiFi interface can be used as a fallback solution for controlling the Charging Robot in case it is offline (no Internet and Easee app support). The touch button may serve additional functions. Please use the online knowledge-base for other possible touch combinations and functions.
- 2. Light strip:** The light strip communicates the status of the Charging Robot at all times. Read more about this on page 11.
- 3. RFID area:** The integrated RFID reader enables access control of the Charging Robot and identification of different users. You can use it to unlock the charger with an Easee Key. Check our knowledge base at [easee.support](#) for more details on how to add and manage your Easee Keys.
- 4. Type 2 socket:** The Type 2 socket is completely universal and allows you to charge any type of electric vehicle using the appropriate charging cable. Furthermore, it is possible to permanently lock the charging cable, so you do not have to worry about it being stolen.

Technical specifications

General

Dimensions (mm): 256 x 193 x 106 (H x W x D)
Wall mounting (mm): c/c 160 x 125 (H x W)
Operating temperature: -30 °C to +50 °C
Weight: 1.5 kg
Warranty: 3 years (warranty may be longer in some countries)

Charging

Charging power: 1.4–22 kW
6 A 1 phase – 32 A 3 phase (automatically adjusted in relation to available capacity)
Up to 7.36 kW at 32 A 1 phase
Up to 22 kW at 32 A 3 phase (TN grid)
Connection point: Type 2 socket (IEC 62196-2)
Number of phases: 1 or 3 (fully dynamic)
Voltage: 3 x 400 V AC/ 230 V AC (±10 %)
Mains frequency: 50/60 Hz
Built-in energy meter (±2 %)
Easee Home: Load balancing of up to 3 units per circuit
Easee Charge: Load balancing of up to 101 units per circuit

Sensors and indicators

Light strip with LEDs showing the status of the charger
Touch button for manual adjustment
Temperature sensors in all main contacts

Connectivity

Built-in eSIM (LTE Cat M1/ 2G /GPRS)
WiFi 2.4 GHz b/g/n connection
Easee Link RF™
Control charging via Easee app
RFID/NFC reader
OCPP 1.6 via our API

Protection

Integrated overload protection according to EN IEC 61851-1:2019
Built-in RCD for ground fault protection (30 mA AC/ 6 mA DC) according to EN 61008-1 and IEC 62955
Degree of protection: IP54 (the backplate is IP22 without cover)
Impact resistance: IK10
Fire class: UL94
Insulation class: II
Overvoltage category III

Safety instructions

Read the entire manual carefully before installing and operating the product. Observe the following instructions:

Safety instructions for operation

- Danger to life due to high electrical voltage. Never make any changes to components, software or connecting cables.
- Never use or touch the product if it is damaged or does not function properly.
- Always have the prescribed maintenance, installation and any repair work carried out by an authorised electrician and in accordance with local requirements.
- If a fire occurs, do not use water for extinguishing.
- Never clean the Charging Robot with high pressure or running water.
- Do not immerse the product in water or other liquids.
- If the light strip on the product lights up red, there is a fault. For more information, see page 11.
- Make sure that children do not play with the product.
- Never touch the contacts of the Type 2 socket and never insert foreign objects into the product.
- Never use the charging cable if it is damaged or if the connections are wet or dirty.
- Do not use extension cords or adapters in combination with the product.
- The charging cable must only be removed from the Charging Robot by pulling the plug handle, not by pulling the cable.
- Make sure the charging cable does not cause a tripping hazard or risk being run over by a car.
- Even if the Charging Robot is designed to withstand normal weather conditions, we recommend protecting it from direct sunlight or exposure to extreme weather conditions.
- Do not use the product near strong electromagnetic fields or in the direct vicinity of radio transmitters.

Installation instructions



WARNING! If the Easee Ready is installed in your private home, we recommend that you turn off the power before continuing the process of installing the Chargeberry. If for some reason it is not possible to turn off the power - for instance, if the charger is part of a shared charging system - be careful and follow the instructions.



In addition to the instructions presented on the next pages, we recommend that you watch the installation video available on our website: easee.support.

1 Easee Ready Opening

1. Unscrew the locking screw at the bottom of the Easee Ready.
2. Insert the two ends of the included tool into the two openings at the bottom of the Easee Ready cover.
3. Pull until the cover comes loose.
4. Lift the cover from the bottom and upwards.

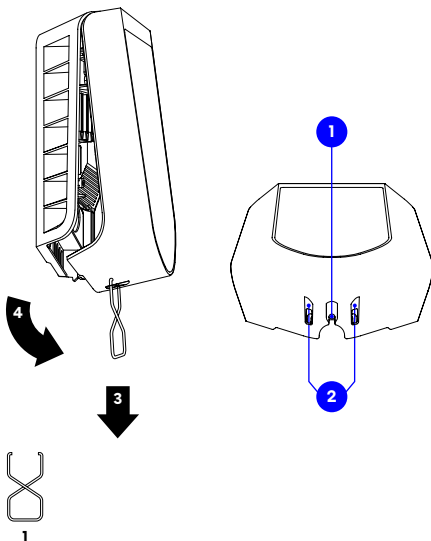

2 Chargeberry Attaching



WARNING! Do not touch the electrical terminals or wires inside the backplate, they are electrically live.

1. Turn on the power. The terminals of the backplates are now electrically live.
2. Position the Chargeberry to fit into the slots on the backplate.
3. When the Chargeberry is in the track, press it forcefully down until you hear a click.
4. Paste the PIN code sticker on the back of the manual or in another safe location, e.g. inside of the fuse cabinet door.

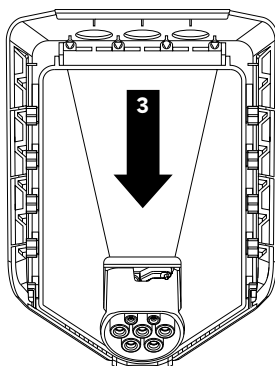
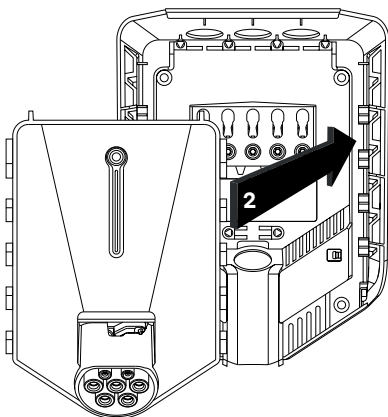

"CLICK!"

3 Front cover Closing

Before closing the front cover, it is possible but optional to lock the Chargeberry with a padlock (see recommended padlock size on page 13). Locking the electronics adds an extra level of security (padlock is not included).

1. Hang the front cover at the top of the backplate and let it fall into place.
2. Press the bottom of the front cover until you hear a click.
3. Bend the lower part of the rubber cover down.
4. Screw in the locking screw at the bottom of the charger to secure the front cover.
5. Close the rubber cover. If the cable is inserted from the bottom, you can cut a corresponding hole in the rubber cover to ensure a neat installation.

Your Charging Robot is now ready for use!

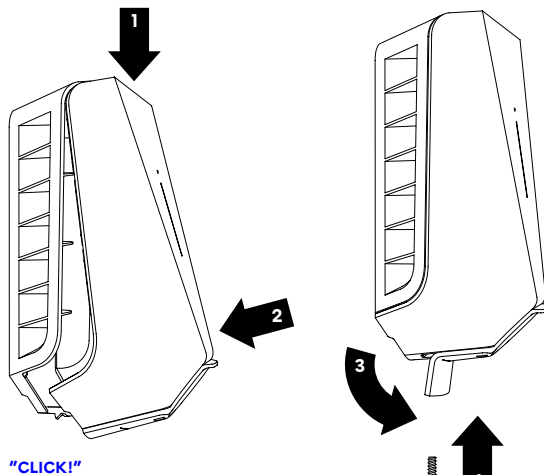
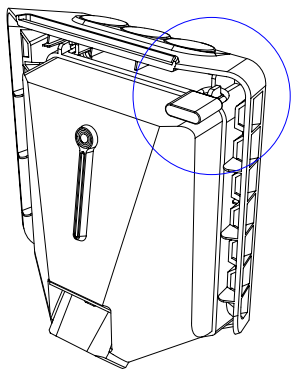

4

How do I charge?

WARNING! Observe the safety instructions on page 6 before using the product.

Make sure that the following requirements are met before using the Charging Robot:

- The authorised electrician have set up the electrical connection properly.
- The charger is properly configured.
- The software is up to date (see page 11).
- If you have set up access control, unlock it by using a registered RFID tag or disable it from the Easee App or the local WiFi interface.

1. Check the charging cable and connector for damage and impurities such as foreign objects and water ingress before charging.
2. Connect the charging cable to the Charging Robot and your electric car. The charging process starts and adapts automatically to the electric car and the available energy at any time according to the configuration.

If the car does not start charging, check that charging is activated in your car and that the connectors are properly plugged in. If charging still does not start, check what might be the cause on page 11.

Smart charging

Some operators offer smart charging which will delay charging to a suitable point in time, often tied to electricity price or similar mechanisms. When Smart charging is active the LED strip is lit blue, charging will not start until the operators criteria for charging is met. Contact you operator to know more and to find out if they offer this service.

Apps and interfaces

WiFi interface

The WiFi interface is intended for local operation of the charger. It is not depended on an internet connection, but it needs a smartphone to be accessed.

Easee app

The Easee app is intended for everyday use of your Easee products. It can be used anywhere in the world through the Easee Cloud.

The Easee app can be downloaded from the application store of your iOS or Android mobile device.



Easee Portal

The Easee Portal is a tool intended for administration of one or several Easee sites.

The Portal is mainly intended for site owners, installers, administrators, service providers and people who need to manage several products and sites from one interface.

Go to [easee.support](#) for more information on our interfaces.

Charging Robot interface

Light description	Status
White - constant light, only at the bottom 2 LEDs - master unit / 1 LED - secondary units	Standby
White - constant light	Car connected
White - pulsating light	Charging in progress
Blue - constant light	Smart charging enabled (car connected)
Blue - pulsating light	Smart charging in progress
At startup, the LEDs turn on one by one. When the charger is updating, one or more LEDs will flash green while this is in progress.	Updating software (updating can take up to 30 minutes) NOTICE! The car must be disconnected before a software update can be completed.
White - flashing light	Waiting for authentication by an RFID tag. Hold the RFID tag against the RFID area of the Charging Robot in order to authenticate and initiate the charging.
White - fast flashing light	RFID-tag received (awaiting key verification)
Red - constant light	General error. Unplug the charging cable and replug it to the Charging Robot. If the red light persists, check the Easee app or our knowledge base ¹ for further information.
Red - constant light, with warning sounds	Wires are connected incorrectly. Consult an authorised electrician.
Red - pulsating light	The Charging Robot has measured an abnormal temperature and has entered in safe mode. Please go to our knowledge base ¹ for further information.
White - flashing light, only at the bottom	The Charging Robot is searching for its master unit. Please check the status of the master unit. For further information, please check our knowledge base ¹ .
Yellow - flashing light, only at the bottom	The Charging Robot is waiting to be configured. Consult an authorised electrician.

¹ Easee public knowledge base can be found at [easee.support](https://www.easee.com/support).

Maintenance

General maintenance

If the product is installed in public spaces and is accessible to everyone, observe local and national requirements (e.g. Norway NEK400 part 6.1) in addition to the procedures below.

- Ensure that the charger does not have any signs of mechanical damage.
- Visually inspect the Type 2 socket for wear and tear at regular intervals according to local regulations. If the pins are discoloured or damaged, please contact your authorised electrician.

Cleaning

The charger does not require cleaning to operate properly. Nevertheless, if the product needs to be cleaned for cosmetic reasons, this is possible.

- Use a damp cloth and an all-purpose household cleaner. Avoid using strong chemicals that contain oil or alcohol, as this may discolour the plastic.
- Do not use running water or high pressure water jets.

Insulation testing (authorised electrician only)



When carrying out periodic insulation testing of a charging circuit, it is recommended that you remove the Chargeberry from its backplate before measuring between all phases joined together towards earth. Testing the circuit insulation with the Chargeberry installed in the backplate may damage the electronics or impact the reading negatively.

Practical details

Warranty

The device is free from material defects and is in accordance with laws and regulations for consumer protection in the country where the product is purchased. All correctly installed Easee hardware is covered by our 3 years* limited warranty. If your charger needs to be repaired within this warranty period, please contact your Easee supplier. Further information can be found at **[easee.support](#)**.

*Some countries may have extended warranty.

Safety

The product shall be installed according to local regulations for low voltage electrical installations. The product is designed and tested according to the EN 61851 standards for electric vehicle conductive charging system. It includes a built-in RCD able to safely break the circuit in the event of a 30 mA AC or 6 mA DC fault in accordance with IEC 61008 and IEC 62955.

Standards

Hereby, Easee AS declares that this product, Easee EV Charging Robot E01-CB, is in compliance with the Low Voltage Directive 2014/35/EU, Radio Equipment Directive 2014/53/EU, EMC Directive 2014/30/EU and RoHS Directive 2011/65/EU.

The full text of the EU Declaration of Conformity is available at the following internet address: **[easee.support](#)**.

Max transmitted power

Radio: 100 mW at 863–870 MHz. **WiFi:** 50 mW at 2.4–2.472 GHz. **GSM:** 2 W at 880–915 MHz, 1 W at 1710–1785 MHz, 200 mW at 703–748 MHz, 832–862 MHz, 880–915 MHz, 1710–1785 MHz and 1920–1980 MHz.

Product life cycle

Transportation: The charger should always be transported within its original packaging. No other items should be stored on top of the box other than Easee chargers. Should the box be dropped or otherwise impacted, a visual inspection should be done in order to verify potential damage.

Storage: The electronics are hermetically sealed and will not get damaged if stored in humid areas. However, in order to preserve the packaging and its contents, we recommend storage in a tempered, dry and well-ventilated area. Relative humidity should not exceed 80% and no corrosive gas should be present. Storage or transportation environment should never exceed the limits provided in the technical specifications of the charger (see page 5).

Dismounting: Perform a factory reset of the device before powering it down. This is done via the Installer app. Dismounting shall only be performed by an authorised electrician. The power supply to the charger must be isolated before dismounting starts. Use the installation guide and follow the steps in reverse in order to dismount the Charging Robot in the correct order.



Disposal: This electronic equipment must not be disposed of in household waste. For the return of old devices, free collection and acceptance points may be available in your vicinity. Observe local regulations for correct and environmentally friendly disposal. If the old electronic equipment contains personal data, you are responsible for deleting it yourself before returning it.

Padlock dimensions

Max total lock height: 56 mm. Shackle height (outer dimension): 19–20 mm. Shackle thickness: 3.2–4 mm.

Data protection

When the product connects to the Internet, personal data is sent to Easee AS. You will receive more information about data protection during the configuration of your Charging Robot.

Repair

If your charger needs to be repaired, please contact your Easee supplier.

Returns and complaints

Contact your distributor or Easee Customer Support regarding the return and complaint of your product.

Customer support

Download the latest manuals, find answers to frequently asked questions and useful documents and videos for your product at [easee.support](https://www.easee.com/support).

Contact details

Easee AS
Grønseveien 19
4313 Sandnes, Norway
Org. nr: 920 292 046

You can find additional contact details for your country at [easee.com](https://www.easee.com).

THIS DOCUMENT CONTAINS INFORMATION THAT IS
SUBJECT TO CHANGE WITHOUT NOTICE.

The latest version of this publication can be downloaded
at <http://easee.support>

No part of this publication may be reproduced or
transmitted in any form or by any means, electronic
or mechanical, including, but not limited to, copying,
recording, retrieving data, or computer networks without
the written permission of Easee AS.

Easee and all other Easee product names and slogans
are trademarks or registered trademarks of Easee AS.
Easee products can be protected by one or more
patents.

All other products and services mentioned may be
trademarks or service marks of their respective owners.

Illustrations of the product and user interface are
exemplary and may differ from the actual appearance.

January 2022 - Version 2.03
© 2019 by Easee AS. All rights reserved.

easee

Easee AS
Grenseveien 19
4313 Sandnes, Norway
www.easee.com